



APC Smart-UPS[®] RT
External Battery Pack
For Use With Models SURT1000XLI and SURT2000XLI
Tower/Rack Mount Convertible

User's Manual
English

1: SAFETY INFORMATION

American Power Conversion Corporation (APC) is the leading national and international manufacturer of state-of-the-art uninterruptible power supplies, redundant switches, power management software, and related equipment. APC products protect hardware, software, and data from the threat of power disturbances in business and government offices throughout the world.

The APC Smart-UPS RT External Battery Pack connects to an APC Uninterruptible Power Supply (UPS) and provides extended protection from electrical blackouts, brownouts, sags, and surges.



Changes or modifications to this unit not expressly approved by the party responsible for compliance could void the warranty.

HANDLING SAFETY

Be careful. Do not lift heavy loads without assistance.



<18 kg (<40 lb)

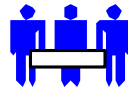

32–55 kg (70–120 lb)



18–32 kg (40–70 lb)



>55 kg (>120 lb)

This equipment is intended for installation in a temperature-controlled indoor area free of conductive contaminants. Refer to Specifications at the APC web site for the actual temperature range.

LIFE SUPPORT APPLICATION POLICY

As a general policy, APC does not recommend the use of any of its products in life support applications where failure or malfunctions of the APC product can be reasonably expected to cause failure of the life support device or to significantly affect its safety or effectiveness. APC does not recommend the use of any of its products in direct patient care. APC will not knowingly sell its products for use in such applications unless it receives in writing assurances satisfactory to APC that (a) the risks of injury or damage have been minimized, (b) the customer assumes all such risks, and (c) the liability of APC is adequately protected under the circumstances.

Examples of devices considered to be life support devices are neonatal oxygen and analyzers, nerve stimulators (whether used for anesthesia, pain relief, or other purposes), autotransfusion devices, blood pumps, defibrillators, arrhythmia detectors and alarms, pacemakers, hemodialysis systems, peritoneal dialysis systems, neonatal ventilator incubators, ventilators for both adults and infants, anesthesia ventilators, infusion pumps, and any other device designated as “critical” by the U.S.F.D.A.

Hospital grade wiring devices and leakage current may be ordered as options on many APC UPS systems, APC does not claim that units with this modification are certified or listed as Hospital Grade by APC or any other organization. Therefore these units do not meet the requirements for use in direct patient care.

BATTERY SAFETY



This equipment contains potentially hazardous voltages that may cause personal injury if handled incorrectly.

This equipment must be installed and serviced only by qualified electrical service personnel.

- This equipment contains potentially hazardous voltages. Do not attempt to disassemble the unit. The unit contains no user serviceable parts. Repairs are to be performed only by factory trained service personnel.
- Do not dispose of batteries in a fire. The batteries may explode.
- Do not open or mutilate batteries. They contain an electrolyte that is toxic and harmful to the skin and eyes.
- Do not connect the terminals of a battery or battery pack with a wire or other electrically conductive objects.
- To avoid personal injury due to energy hazard, remove wristwatches and jewelry such as rings when replacing the batteries. Use tools with insulated handles.
- Replace batteries with the same number and type of batteries as originally installed in the equipment.

BATTERY REPLACEMENT AND RECYCLING

See your dealer or visit the APC web site, www.apc.com/support, for information on replacement battery kits and battery recycling.



Be sure to return the spent battery to APC for recycling. Ship it to APC in the replacement battery packing material.

2: INSTALLING THE BATTERY PACK

The APC Smart-UPS RT External Battery Pack provides extended protection to safeguard your computer and other valuable electronic equipment. The external battery pack also provides extra protection while replacing the batteries in the UPS.

MAXIMUM NUMBER OF BATTERY PACKS SUPPORTED BY THE UPS

The Smart-UPS RT can support an unlimited number of external battery packs. Battery pack connectors are color-coded and keyed to prevent improper connection. Models SURT1000XLI and SURT2000XLI both use battery pack model SURT48XLBP. Both are designed to operate in the tower configuration and rack mount configuration.

UNPACKING

1. Inspect the battery pack upon receipt. APC designed robust packaging for your product. However, accidents and damage may occur during shipment. Notify the carrier and dealer if there is damage.

The packaging is recyclable; save it for reuse or dispose of it properly.

2. Check the package contents. The shipping package contains the battery pack, its front bezel (packaged separately), mounting foot expansion piece, rear bracket tie, and a literature kit containing product documentation.



The battery pack is shipped with the front bezel removed (packaged separately within the main box). You will install the plastic bezel during the installation procedure.

POSITIONING THE BATTERY PACK

Place the battery pack where it will be used. **The battery pack is heavy. Select a location sturdy enough to handle the weight.**

Consider that you must install the battery pack in a protected area that is free of excessive dust and has adequate airflow. Ensure the air vents on the front and rear of the battery pack are not blocked. Allow at least one inch of space on both sides.

Do not operate the UPS where the temperature and humidity are outside the specified limits. Refer to Specifications at the APC web site.

PLACEMENT

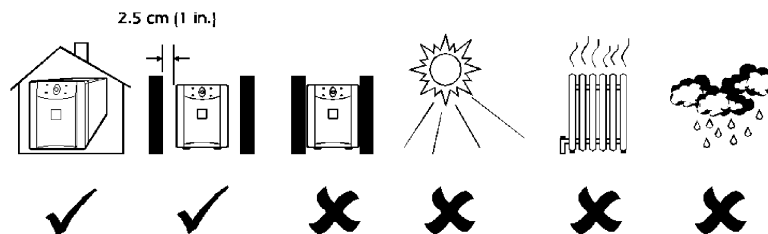

REVIEWING CONNECTORS ON THE BATTERY PACK AND UPS

The UPS and battery pack(s) can be installed together in the tower configuration. The Front View shows what the units look like after installation. The Rear View shows the same units – the battery pack connection cable plug is not yet engaged in this view. Only one external battery pack is shown here.

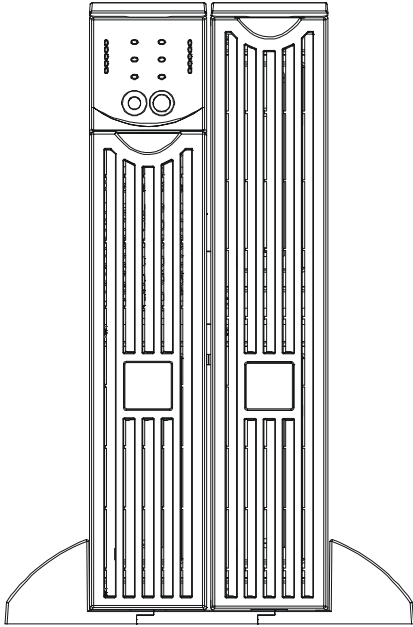

UPS Battery Pack
Front View

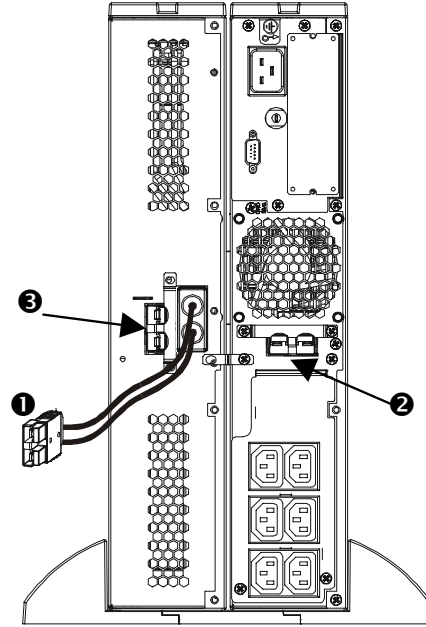

Battery Pack UPS
Rear View

Connection Cable plug

The connection cable plug ❶ is to be attached into either a battery pack connector on the UPS ❷, or another battery pack if daisy-chaining more than one battery pack together. The connector is color-coded and keyed to prevent improper connection.

Battery Pack Connector

Use the battery pack connector ❸ to daisy-chain multiple battery packs to the same UPS. The connector is color-coded and keyed to prevent improper connection.

INSTALLING THE BATTERY PACK

To install one or multiple battery packs in the tower configuration, follow these basic steps.

REMOVE AND EXPAND THE UPS FEET

The UPS is heavy, remove the battery tray to lighten it. Instructions to remove the battery tray and the feet can be found in your UPS User's Manual.

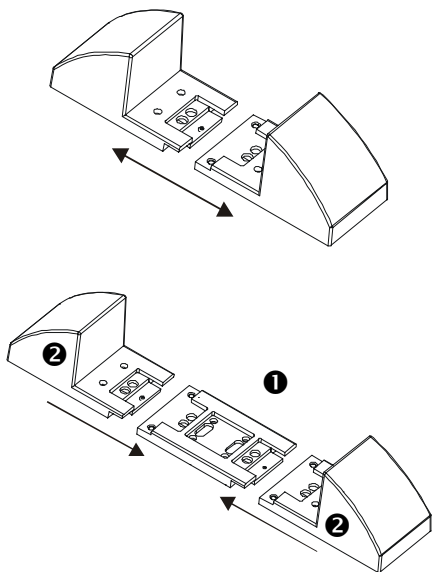

1. Once the feet have been removed, snap apart each foot into two end brackets.
2. Each foot needs one expansion piece ❶ for each external battery pack you are using. Additional expansion pieces are shipped with the external battery packs. Snap all center expansion pieces together, and then snap the brackets ❷ back onto the ends of the expansion piece(s) to complete the foot. Repeat with the other foot.

REMOVING THE BATTERY TRAYS FROM THE BATTERY PACK

The battery pack is heavy. To lighten it, remove the battery trays. Battery trays in your external battery pack are installed and removed just like the battery tray found in your UPS.

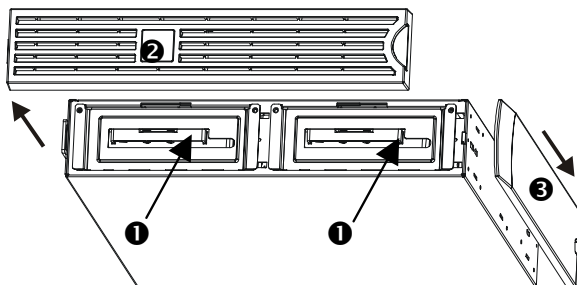

The battery trays are accessible from the front of the battery pack (shown at left). This procedure requires a Phillips screwdriver.

1. Notice that two battery tray compartments ❶ are visible. The External Battery Pack is shipped with the bezel ❷ removed, but the top decorative panel ❸ attached.
2. If your external battery pack has been in operation, you will need to remove the top decorative panel and front bezel before gaining access to the battery compartments. Remove them using instructions found in your *UPS User's Manual*.
3. Continue following instructions in the *UPS User's Manual* section *Remove and Reinstall Battery Pack* to remove the battery doors, disconnect batteries (if the battery pack has been in use; the batteries are shipped disconnected) and remove the battery trays.

POSITIONING THE BATTERY PACK AND UPS



If more than 2 external battery packs are to be connected to the UPS, you will need more than one person to properly support and rotate the attached units during the installation, even after removal of all battery trays.

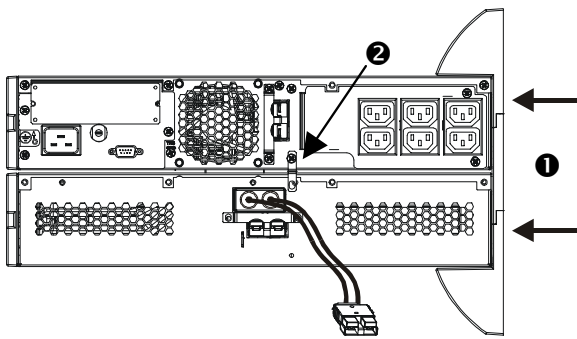

1. Position the UPS on the battery pack(s). Reattach the expanded feet ❶ according to the instructions in your *UPS User's Manual*. Screw the feet firmly into both the UPS and each battery pack.
2. Screw the rear bracket tie(s) ❷ in place between the external battery pack and the UPS, and between each external battery pack if you are daisy chaining more than one battery pack to your UPS.
3. Carefully rotate the whole attached unit upright onto the feet.
4. Reinstall the battery trays into the UPS and battery packs. Be certain to connect the batteries. Reattach the front bezels and top cover panels. Instructions for these steps can be found in your *UPS User's Manual*.

CONNECTING THE BATTERY PACK TO THE UPS



Battery pack connectors are color-coded and keyed to prevent improper connection. The color of the connector on the UPS must match the color of the battery pack connector.



Allow the battery pack to charge for 24 hours. **Do not** expect full run time during this initial charge period.

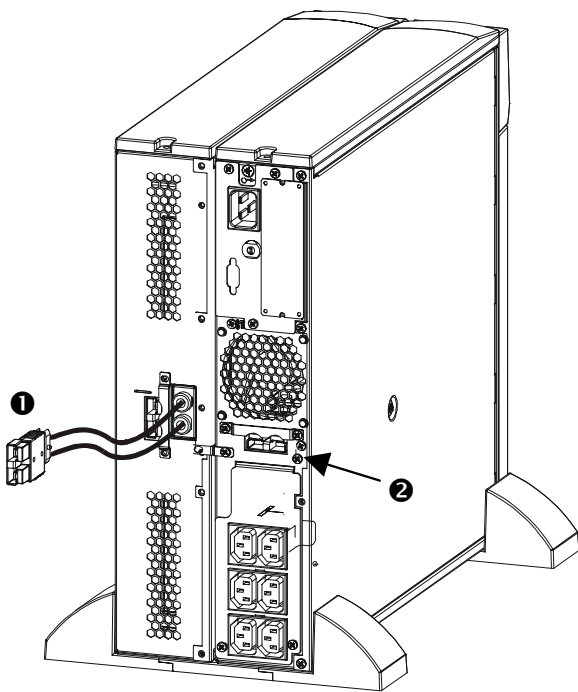

1. Insert the battery pack connector plug ❶ into the rear connector ❷ on the back of the UPS.

CONNECTING A BATTERY PACK TO ANOTHER BATTERY PACK

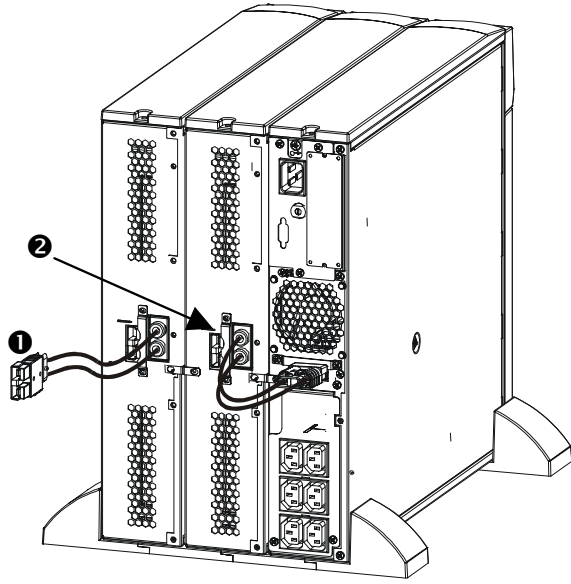

1. Insert the battery pack connector cable plug ❶ into the rear connector ❷ on the back of the other battery pack. Note that the illustration at left shows the UPS and the first external battery pack properly connected.

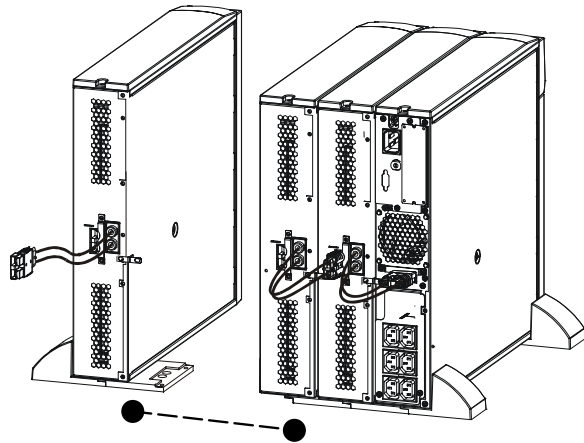

An unlimited number of external battery packs can be attached and daisy-chained together in this fashion.

MOUNTING THE BATTERY PACK IN A RACK

To install one or multiple battery packs into a rack mount, you need to obtain a *Rail Kit* (Part # SURTRK). The *Rail Kit* to mount a Smart-UPS RT UPS and External Battery Pack is the same. Mount your external battery pack exactly as you would a UPS, except the battery pack will have two battery trays to remove and replace instead of one. There is no control panel on the external battery pack to rotate.

3: OPERATING THE SMART-UPS RT WITH A BATTERY PACK

SETTING THE SMART-UPS RT TO RECOGNIZE THE BATTERY PACK(S)

Smart-UPS RT models cannot determine how many external battery packs are connected to them. You must program the Smart-UPS RT with the appropriate number of external batteries in one of two ways by using:

- PowerChute[®] *plus* Version 5.x for Windows 95, Windows 98, or Windows NT
- A terminal program to change the number of external battery packs

Each method is described in this section.



It is important to follow these instructions. The number of batteries affects the run time calculations the Smart-UPS RT performs when it is running on battery power.

USING POWERCHUTE[®] PLUS VERSION 5.X FOR WINDOWS 95, WINDOWS 98, WINDOWS NT

PowerChute *plus* 5.x for Windows NT is compatible with NT 3.5.1 SP5, NT 4.0 Workstation (at least SP1), or NT 4.0 Server (at least SP1).

1. Install the software per the instructions on the CD. After rebooting the computer, access the PowerChute *plus* graphical user interface.
2. Click on **Configuration**.
3. Click on **UPS Operating Parameters**.
4. Adjust the **External Battery Pack** field to the appropriate number of external battery packs.
5. Click **OK**.

USING A TERMINAL PROGRAM TO CHANGE THE NUMBER OF EXTERNAL BATTERY PACKS

1. **EXIT** the PowerChute *plus* Server if running. In Windows NT, the UPS Service must be stopped.
2. Open a terminal program. For example to open Hyperterminal in Windows NT:
From the Desktop, go to **Start => Programs => Accessories => Hyperterminal**. Double-click on the **Hyperterminal** icon. You are prompted to choose a name and select an icon. Enter name and then click **OK**. Disregard the message, "...must install a modem," if it is displayed.
3. Select the COM port. The port settings are 2400 baud, 8 data bits, 1 stop bit, no parity, flow control off.
4. Once the terminal window is open, follow these steps to enter the number of external battery packs using the terminal mode within the Smart-UPS RT:

Hit the Enter key to initiate terminal mode. Following the prompts:

Hit 1 to modify UPS Settings. Hit e (or E) to modify the number of external battery packs. Enter the number of external battery packs only (don't count the internal battery pack) followed by the Enter key. Enter YES (must be upper case) followed by the Enter key to confirm the new setting. Hit any key to continue. Hit the Esc key to return to the main menu. Hit the Esc key again to logout of terminal mode.

5. Exit the terminal program.
6. Restart the PowerChute *plus* Server if desired. In Windows NT, the UPS Service must be restarted if desired.

4: STORAGE, SERVICE, AND CONTACT INFORMATION

STORAGE

STORAGE CONDITIONS

Store the battery pack covered and flat (rack mount orientation) in a cool, dry location, with its battery fully charged. Disconnect battery cables to avoid drain on batteries.

EXTENDED STORAGE

At -15 to +30 °C (+5 to +86 °F), charge the batteries every six months.

At +30 to +45 °C (+86 to +113 °F), charge the batteries every three months.

REPLACING A BATTERY TRAY

The battery pack has two easy to replace, hot-swappable battery trays. Battery tray replacement is a safe procedure, isolated from electrical hazards. You may leave the battery pack connected to the UPS with the protected equipment when replacing battery trays. See the APC website <http://www.apc.com/support>, to confirm the correct replacement battery tray number (RBC) and to see other options. Follow the instructions in your UPS *User's Manual* and in this manual in the *Installation* section.

DECLARATION OF CONFORMITY

2002

Date of product declaration

CE Declaration of Conformity

We, the undersigned, declare under our sole responsibility that the equipment specified below conforms to the following standards and directives:

Standards to Which Conformity Declared: EN 50091-1-1,1-2, EN 55022, EN 6100-3-2, 3-3, 4-2, 4-3, 4-4, 4-5, 4-6, 4-11, EN 60950, IEC 60950

Application of Council Directives: 73/23/EEC, 89/336/EEC

Type of Equipment: Power Supply

Model Numbers: SURT48XLBP

Manufacturer's Name and Address: American Power Conversion
132 Fairgrounds Road
West Kingston, Rhode Island, 02892, USA
-or-
American Power Conversion (A. P. C.) b. v.
Ballybritt Business Park
Galway, Ireland

-or-

American Power Conversion

2nd Street

PEZA Cavite Economic Zone

Rosario, Cavite

Philippines

-or-

American Power Conversion

Main Avenue, Peza

Rosario, Cavite, Philippines

-or-

APC (Suzhou) UPS Co., Ltd

339 Suhong Zhong Lu

Suzhou Industrial Park

Suzhou Jiangsu 215021

P R China

Importer's Name and Address: American Power Conversion (A. P. C.) b. v.
Ballybritt Business Park
Galway, Ireland

Place: N. Billerica, MA U.S.A.

Richard J. Everett, Sr. Regulatory Compliance Engineer

 5 Jan 02

Place: Galway, Ireland

Ray S. Ballard, Managing Director, Europe

 5 Jan 02

SERVICE

If the unit requires service, do not return it to the dealer. Instead, follow these steps:

1. Review the problems discussed in the *Troubleshooting* section of the User's Manual for your UPS to eliminate common problems.
2. Verify that no circuit breakers are tripped. A tripped circuit breaker is the most common problem.
3. If the problem persists, call APC Customer Service or visit the APC website (www.apc.com).
 - Note the model number of the unit, the serial number, and the date purchased. If you call APC Customer Service, a technician will ask you to describe the problem and try to solve it over the phone, if possible. If this is not possible the technician may arrange for the unit to be serviced or may issue a Returned Material Authorization Number (RMA#).
 - If the unit is under warranty, repairs are free. If not, there is a repair charge.
 - Procedures for servicing or returning your unit may vary internationally. Please contact the APC Customer Service office in the appropriate country (www.apc.com/support) for questions about warranty and RMA.
4. Pack the unit in its original packaging. If the original packing is not available, ask APC Customer Service about obtaining a new set.

Pack properly to avoid damage in transit. Never use Styrofoam beads for packaging. Damage sustained in transit is not covered under warranty.



Always DISCONNECT THE BATTERY before shipping in compliance with U.S. Department of Transportation (DOT) regulations.

5. Mark the RMA# on the outside of the package.
6. Return the unit by insured, prepaid carrier to the address given to you by Customer Service.

CONTACTING APC

Refer to the information provided at the APC Internet site:

<http://www.apc.com/support/contact>

LIMITED WARRANTY

See your UPS User's Manual for the Limited Warranty for both the UPS and your External Battery Pack(s).